

## 2016-18 CHEVY SILVERADO 1500 HID LED RH LWR OUTBOARD HEADLIGHT TAB KIT P/N 25-10039

(Please visit [CreativeRepairSolutions.com](http://CreativeRepairSolutions.com) for detailed instruction videos.)

KIT CONTENTS		QTY	TOOLS REQUIRED	
20-10013 RH LWR OUTBOARD HEADLIGHT TAB	1	PROTECTIVE EYEWEAR	SCUFFING OR SANDING PAD	
#8 X .625 PAN HEAD SCREW (A)	2	SCREW GUN OR DRILL PH1	ALCOHOL PRE-CLEANER	
ADHESIVE PIPETTE	1	CUT-OFF WHEEL	MEASURING DEVICE	
22-10006 U-NUT	1	DA SANDER		

**1. Trim:** Using a cut-off wheel, trim the damaged tab to the **MAX** dimension whenever possible. Make note that in this case the trimming line is both the **MIN** and **MAX** dimension, **Fig. 1**. Trim flush to the plane marked **MIN MAX**, **Fig. 2**. Next, Sand rough edges to remove excess material from trimming and to ensure a proper fit.

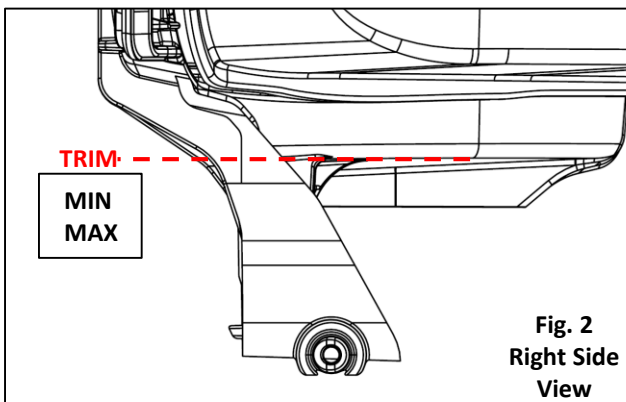
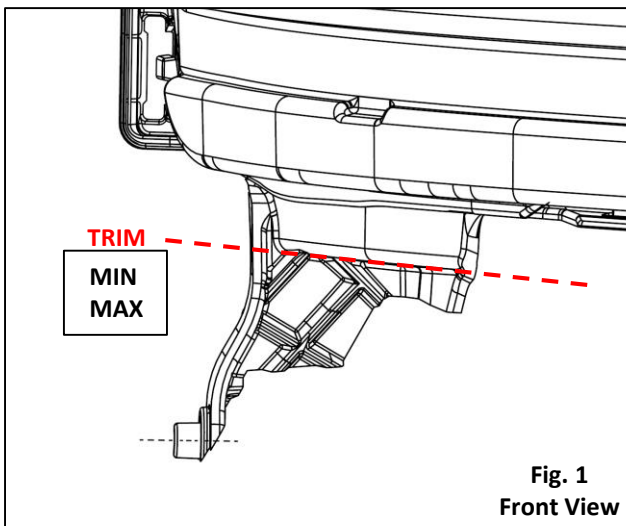

**2. Dry-Fit:** Dry-fit the repair tab(s) **Fig. 3**. If the tab fits without resistance and makes a flush fit to the housing, trimming is complete. If the tab resists installation re-trim the damaged tab, removing only small amounts of material. Repeat the Dry-Fit steps until the proper fit is achieved.

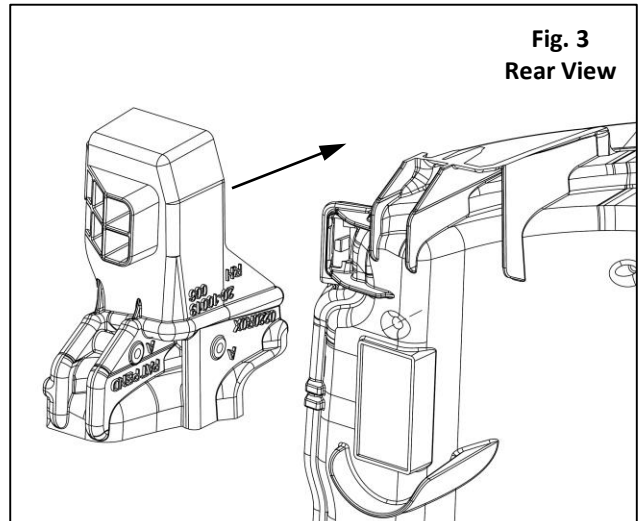

**3. Scuff & Glue:** Scuff the housing and tab(s) using a sanding pad. Remove sanding dust using compressed air. Wipe down the housing and tab(s) using a pre-cleaner to ensure surfaces are free from oil and debris. Apply glue to both the housing and tab(s).

**4. Install:** Install the prepared tab(s) ensuring a flush fit to the housing **Fig. 4**. Next, drive the 5/8" screws at the locations marked **(A)**. Do not over-tighten the screws. Allow the glue to cure for approximately 30 minutes before installing the repaired headlight on the vehicle.

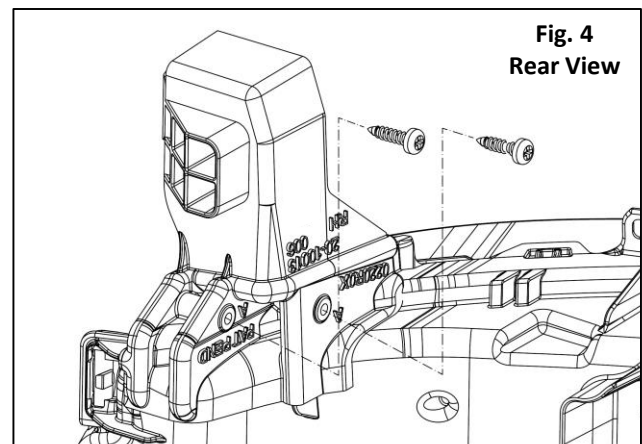

SEE REVERSE SIDE for views of properly trimmed headlamp tab.

