

2016-18 CHEVY SILVERADO 1500 HID LED RH UPR OUTBOARD HEADLIGHT TAB KIT P/N 25-10038

(Please visit CreativeRepairSolutions.com for detailed instruction videos.)

KIT CONTENTS	QTY	TOOLS REQUIRED	
20-10011 RH UPR OUTBOARD HEADLIGHT TAB	1	PROTECTIVE EYEWEAR	SCUFFING OR SANDING PAD
20-10012 RH UPR OUTBOARD HEADLIGHT TAB CVR	1	SCREW GUN OR DRILL PH1	ALCOHOL PRE-CLEANER
#8 X .625 PAN HEAD SCREW (A1), (A2), (A)	4	CUT-OFF WHEEL	MEASURING DEVICE
ADHESIVE PIPETTE		DA SANDER	

1. Trim: Using a cut-off wheel, trim the damaged tab to the **MAX** dimension whenever possible, **Fig. 1**. Make note of the trimming plane to which the **MAX** dimension refers, **Fig. 2**. The **MIN** indicates the least amount of material allowed for proper screw engagement. Next, Sand rough edges to remove excess material from trimming and to ensure a proper fit.

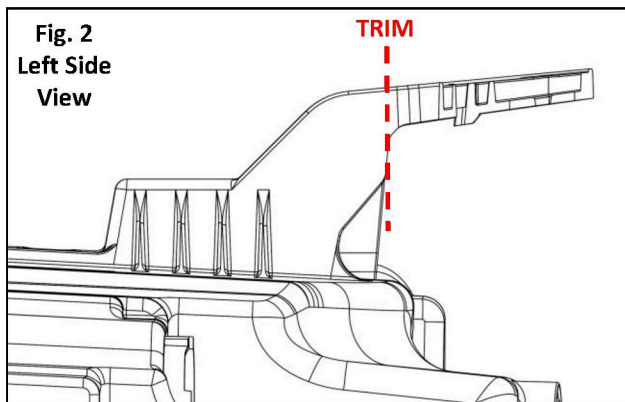
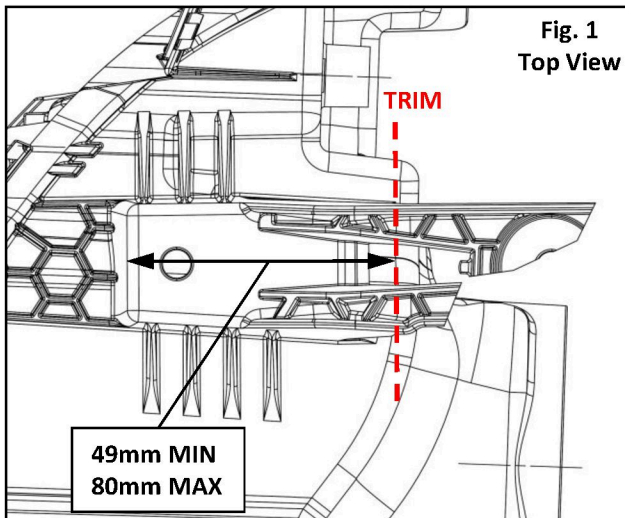

2. Dry-Fit: Dry-fit the repair tab(s) **Fig. 3**. If the tab fits without resistance and makes a flush fit to the housing, trimming is complete. If the tab resists installation re-trim the damaged tab, removing only small amounts of material. Repeat the Dry-Fit steps until the proper fit is achieved.

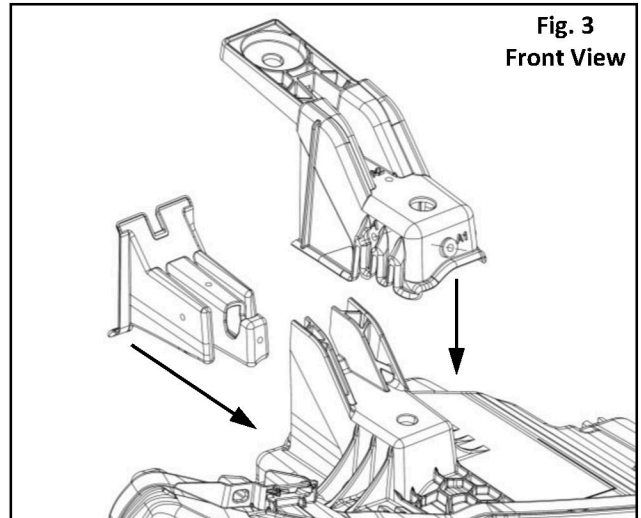

3. Scuff & Glue: Scuff the housing and tab(s) using a sanding pad. Remove sanding dust using compressed air. Wipe down the housing and tab(s) using a pre-cleaner to ensure surfaces are free from oil and debris. Apply glue to both the housing and tab(s).

4. Install: Install the prepared tab(s) ensuring a flush fit to the housing **Fig. 4**. Drive the 5/8" screws at the locations marked **(A1)**, followed by **(A2)** then location **(A)**. Do not overtighten the screws. Allow the glue to cure for approximately 30 minutes before installing the repaired headlight on the vehicle.

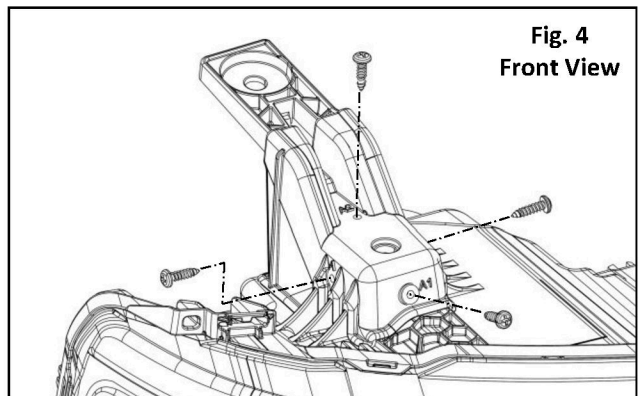

SEE REVERSE SIDE for views of properly trimmed headlamp tab.

